

### Merkmale

- Sicherheitsschalter mit Zwangsbetätigung
- Gutachtliche Beurteilung G 328 (TÜV) für EN 81
- Gehäuse aus Thermoplast, selbstverlöschend
- großzügiger Einlauf bei kleinem Schwenkradius am Hakenriegel
- hohe Kontaktsicherheit durch Selbstreinigung
- geräuscharme Funktionsweise
- sehr lange Lebensdauer
- Druckscheibe zur sicheren Befestigung

### Features

- safety switch with positive contact
- authoritative judgement G 328 (TÜV) for EN 81
- enclosure thermoplastic, self-extinguishing
- large-scale feed opening at small swivelling radius suit the door mechanism
- high contact safety by self-cleaning
- quiet functioning
- very long service life
- pressure plate for secure fixation

### Bestellangaben / Order Information Codes

<b>HZ</b>	Sperrmittelschalter für Hakenriegel / switch for locking mechanism
<b>PZ 18</b>	Kontaktbrücke, 18 mm hoch / contact bridge, 18 mm high
<b>PZ 21</b>	Kontaktbrücke, 21 mm hoch / contact bridge, 21 mm high
<b>PZ 24</b>	Kontaktbrücke, 24 mm hoch ( <i>nicht berührungssicher, IP 00</i> ) / contact bridge, 24 mm high ( <i>not protected against accidental contact, IP 00</i> )
<b>PZ 18SO</b>	Kontaktbrücke sonder (quer), 18 mm hoch / contact bridge special (diagonal), 18 mm high
<b>PZ - U1</b>	Unterlage, 1 mm dick für PZ 18, PZ 21, PZ 24 / pad, 1 mm thick for PZ 18, PZ 21, PZ 24
<b>PZ - U5</b>	Unterlage, 5 mm dick für PZ 18, PZ 21, PZ 24 / pad, 5 mm thick for PZ 18, PZ 21, PZ 24
<b>PZ - A</b>	Anreißlehre für Kontaktbrücke PZ 18, PZ 21, PZ 24 / marking device for contact bridge PZ 18, PZ 21, PZ 24





## Geräteabmessungen / Device Dimensions

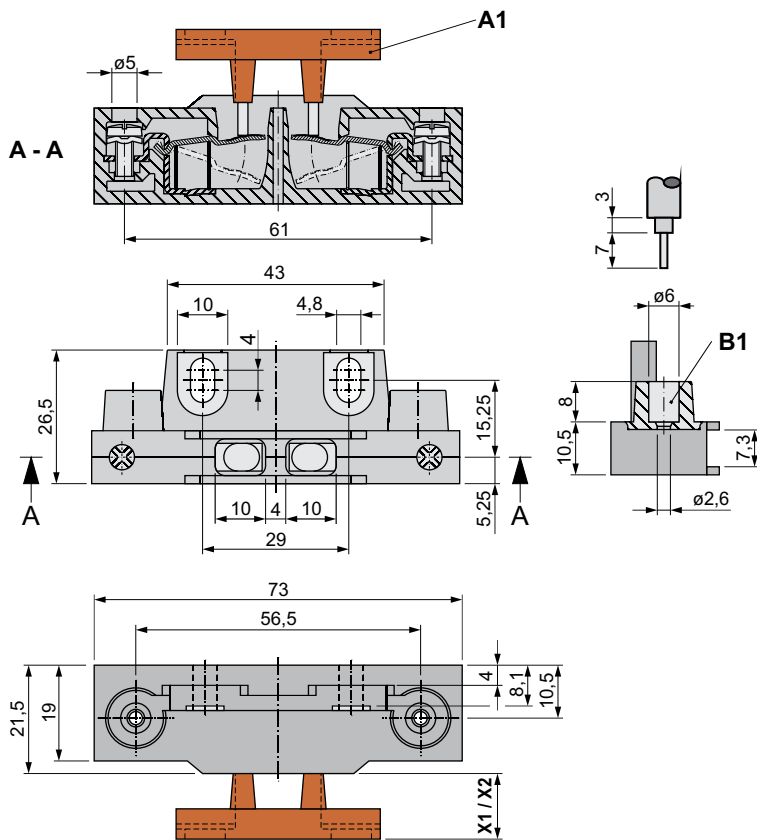

- A1 Kontaktbrücke / contact bridge  
B1 Leitungseinführung einadrig, max.  $\varnothing$  6 mm / cable entry single core, max.  $\varnothing$  6 mm  
X1 Beginn der Kontaktgabe / start of the contact making  
X2 voller Durchhub am Kontakt / full stroke at contact

	PZ 18	PZ 21	PZ 24 <sup>2)</sup>
X1	10	13	16
X2	6	6	9
X1-X2 <sup>1)</sup>	4	7	7

<sup>1)</sup> max. Durchhub / max. overtravel

<sup>2)</sup> nicht berührungssicher IP 00 / not protected against accidental contact IP 00

### Technische Daten:

<b>Normen</b>	EN 81-1 / 81-2 ; EN 60947-5-1 U <sub>i</sub> = 500 V I <sub>th</sub> = 10 U <sub>imp</sub> = 4 kV
<b>Schaltleistung</b>	AC-15 I <sub>e</sub> = 2 A U <sub>e</sub> = 230 V DC-13 I <sub>e</sub> = 2 A U <sub>e</sub> = 200 V
<b>Kurzschlußfestigkeit</b>	T 10 A; F 16 A
<b>Schutzart</b>	IP20, IP00 bei Verwendung der Kontaktbrücke PZ 24
<b>Kontakte</b>	Zwangsöffner mit Feinsilber als Kontaktwerkstoff
<b>Anschluss</b>	über Schraubklemme max. 2,5 mm <sup>2</sup> , unverlierbar
<b>Umgebungstemperatur</b>	-30 °C bis 80 °C, Einbaulage beliebig
<b>Betätigungskraft</b>	1,6 N
<b>Gewicht</b>	HZ = 26 g (PZ 18 = 6 g PZ 21 = 6,2 g PZ 24 = 6,4 g)

### Technical Data:

<b>norms</b>	EN 81-1 / 81-2 ; EN 60947-5-1 U <sub>i</sub> = 500 V I <sub>th</sub> = 10 A U <sub>imp</sub> = 4 kV
<b>switching capacity</b>	AC-15 I <sub>e</sub> = 2 A U <sub>e</sub> = 230 V DC-13 I <sub>e</sub> = 2 A U <sub>e</sub> = 200 V
<b>short-circuit capacity</b>	T 10 A; F 16 A
<b>level of protection</b>	IP20, IP00 when using the contact bridge PZ 24
<b>contacts</b>	positive contact with refined silver as contact material
<b>connection</b>	by screw terminal max. 2.5 mm <sup>2</sup> , captive
<b>ambient air temperature</b>	-30 °C to 80 °C, installation any operating position
<b>actuation force</b>	1.6 N
<b>weight</b>	HZ = 26 g (PZ 18 = 6 g PZ 21 = 6.2 g PZ 24 = 6.4 g)